

SFMS

SENSORS AND FLUID MANAGEMENT SYSTEMS

AMETEK®

ENGINE COMPONENTS & ACCESSORIES

Engine Lube Systems

System Integration

AMETEK has been providing Lube System components for aircraft engines of all sizes for over forty years. AMETEK is a demonstrated leader in providing cost effective component reliability and performance.

Complete System Capability

AMETEK supplies system components for all lube oil sensing and control functions. AMETEK manages the integration of all system elements including pumps, heat exchangers, filter modules, reservoirs as well as all necessary sensors. Having the widest selection of sensors available under one banner allows for the most cost effective system integration of functional elements. AMETEK has the knowledge and experience with system requirements to manage a low risk implementation. AMETEK works with some of the industry's leading manufacturers of lube system components combined with our sensors to offer the customer the best performance at an affordable price.

- Level Sensors
- Pressure Transducers and Switches
- Temperature Probes
- Reservoirs

Typical System Trade Studies

With basic system requirements for flow-rates and pressures, AMETEK and its partners can size the various components of the system. AMETEK works with the configurations or structures group at the engine manufacturer to establish size and weight constraints. With these requirements, basic system analysis and functional integration trade-offs can begin.

- Thermal Load-Heat Exchanger Sizing
- Pump Sizing and Control Scheme
- Reservoir Sizing and Sensor Integration
- Filter and Bypass Valve Integration

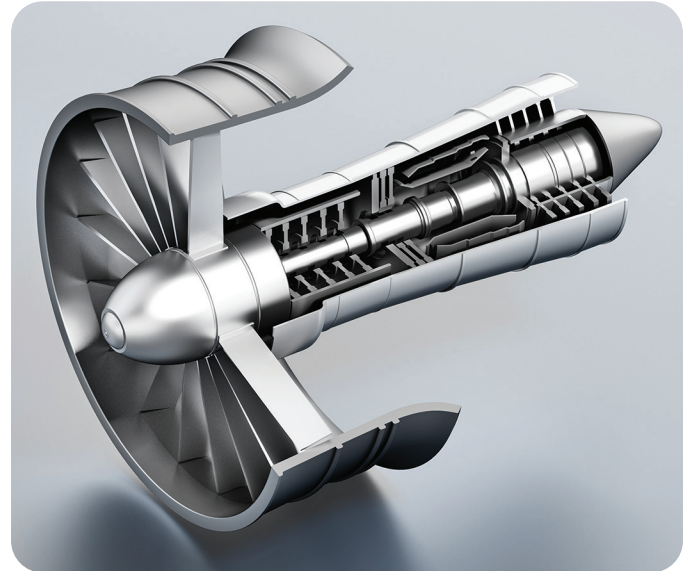

Features

- Fully integrated scheme including all functional elements not just bits and pieces
- Single program management contact coordinating all system contributors
- Performance verified at system level
- Optimized component selection and integration for lowest weight and cost
- Schedule and cost risk reduced through system level qualification testing

www.ameteksfms.com

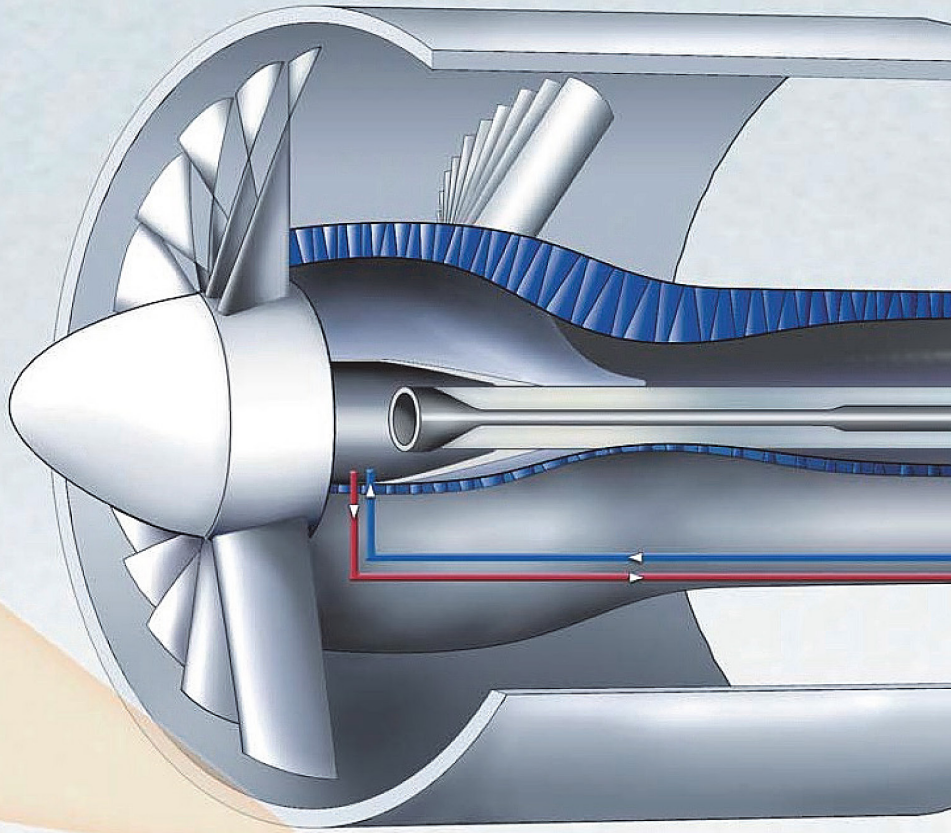

Differential Pressure Switch



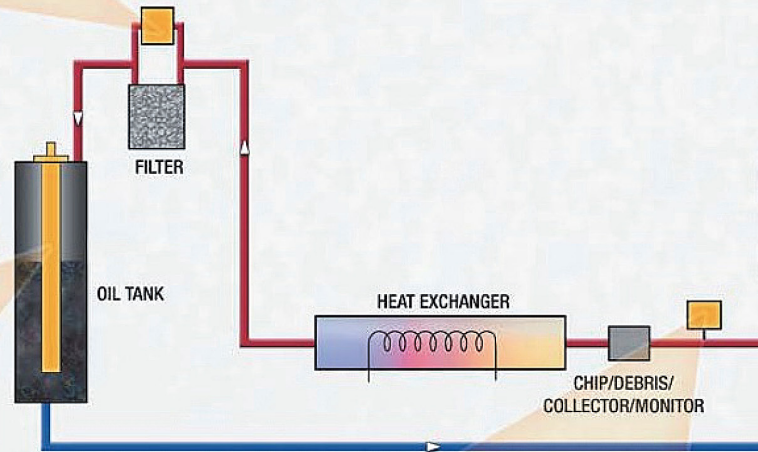

- *Hermetically-sealed outputs*
- *Available with output redundancy*
- *Maintains low contact resistance for operating life*



Oil Level Transmitter

- *Reliability in excess of 200,000 hours*
- *Thousands of units in the field*
- *Available with reed switch or capacitance technology*



-  Supply Line
-  Scavenge Line
-  AMETEK Lube System Parts
-  AMETEK Alliance Sourcing

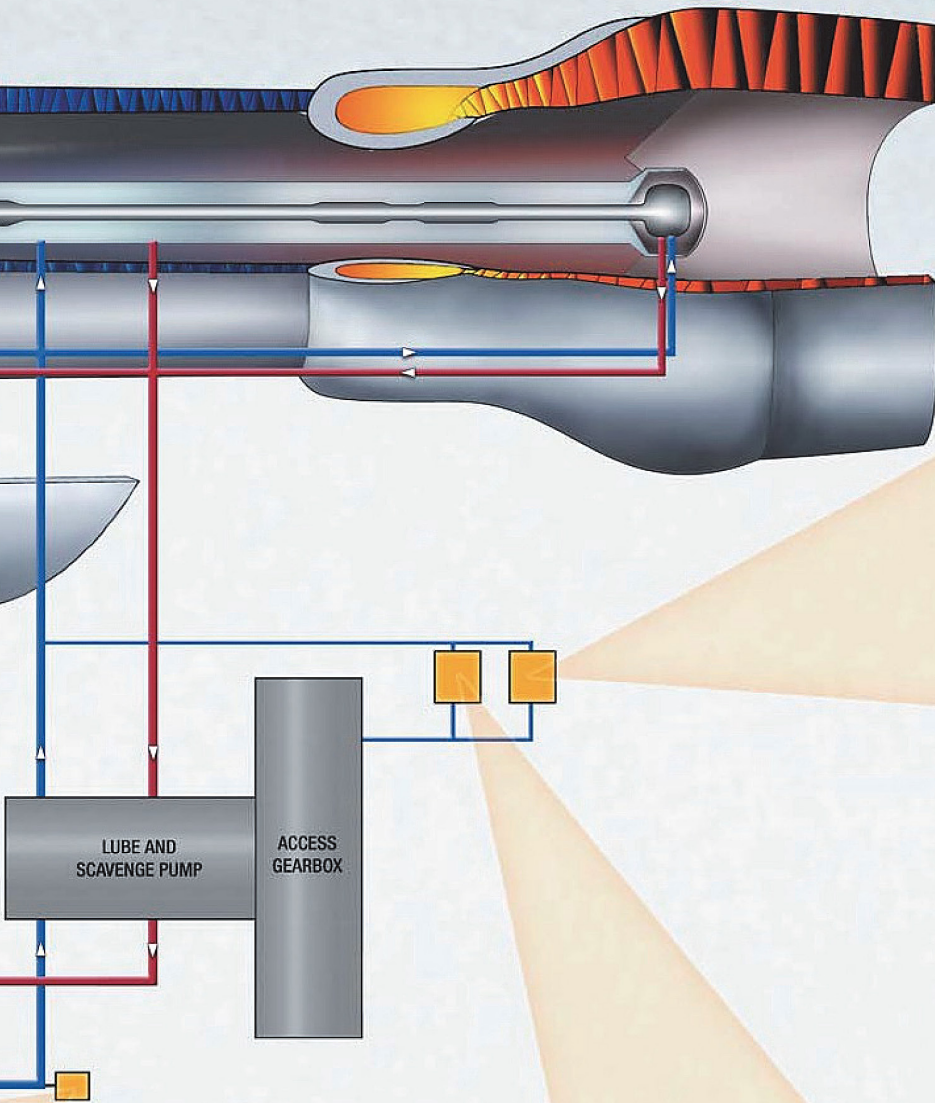

Low Oil Pressure Switch

- *Extremely reliable reed switch technology*
- *Fluorosilicone diaphragm for long life*
- *Maintains low contact resistance over operating life*

Oil Temperature Probe

- *Rugged construction*
- *Rated for 60 Gs vibration*
- *Available with thermocouple or RTD sensing elements*



Pressure Transducer

- *Superior performance, accuracy, and reliability*
- *Low power consumption*
- *Durable, light weight, and compact design*

Finite Element Analysis Capabilities

AMETEK engineers extensively utilize Finite Element Analysis to perform design verification analyses during the early stages of product development. These analyses include:

- Static and Transient Loading
- Natural Frequency and Mode Shapes
- Dynamic Response
- Heat Transfer

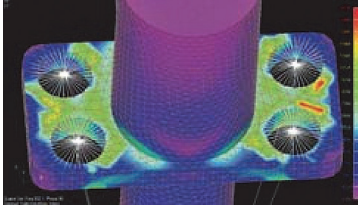

Solid Modeling Capability

Three-dimensional solid modeling tools are extensively utilized during the design and development of AMETEK Aerospace components.

- Design Verification
- Electronic Mock Ups
- Mass Property Analysis
- Finite Element Analysis



Computational Fluid Dynamics (CFD)

The use of CFD analysis software allows AMETEK to understand key flow parameters for both system and component design.

- Compressible and Incompressible Fluids
- Rotary Motion Problems
- Two Phase Flow, Turbulent and Laminar Flow regimes
- Curved Surface and Axisymmetric Geometry

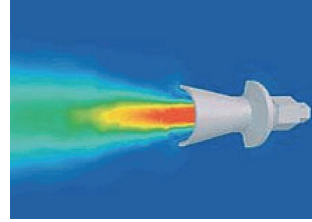

Materials Laboratory

Our Materials Laboratory gives AMETEK a large selection of material analysis test capabilities that range from metallurgical evaluation to hardness testing. These capabilities include:

- X-Ray
- Infrared Spectroscopic Analysis
- Tension/Compression Testing
- Metallurgical Preparation with Final Polishing
- Macro/Micro Photographic and Microscopic Capabilities
- Video Digital Imaging
- Zeiss Axiophot Metallographic Microscope
- Zeiss SV-8 Stereomicroscope

Qualification Testing

Qualification testing includes preparation of test plans, performance of tests under closely controlled conditions, and the issuance of formal reports. Reliability testing includes simulated life tests of instruments and components over extended periods of time. A close working relationship is maintained with several local, independent testing facilities to provide any services not immediately available within AMETEK's laboratory itself. In-house environmental testing includes:

- Temperature, Altitude and Humidity
- Flow Testing
- Mechanical Shock
- Vibrations
- Pressure
- Sustained Acceleration



www.ameteksfms.com

© 2024 AMETEK Corporation. All Rights Reserved. Specifications are subject to change without notice. Other company names and product names used in this document are the registered trademarks or trademarks of their respective owners.

SFMS-DS-10027A - 03/24